

DPW Pallet Scales

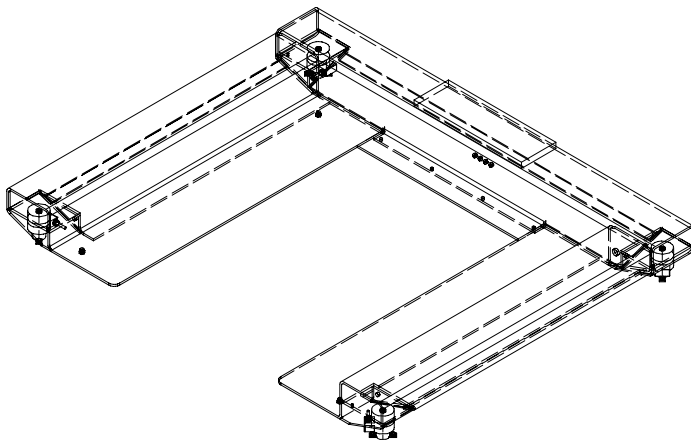

- **Low access height for Hand-Pallet-Truck**
- **Robust and Maintenance-Free**
- **High Quality Manufacture**
- **Available in AISI 316Ti Stainless steel**
- **Extensive Range of Accessories**
- **Legal-for-Trade as a Class III Trade Scales**
- **Also Available as an ATEX Design**

Applications

The robust and maintenance-free design of DPW Pallet Scales makes them suitable for applications in almost all areas of industry.

Paired with the appropriate scales electronics from the DISOMAT family they can also be used as a self-acting scales for automatic gravimetric filling of big bags.

The high-quality design of the scales, the easy access for cleaning and the extensive range of accessories also allow them to be used in exacting applications such as the chemicals industry and for the manufacture of foodstuffs.

Design

- **2 Sizes:** 1080 mm x 1250 mm and 1350 mm x 1250 mm
- **Material:**
 - Powder-coated steel 37 (as per DIN 4753, RAL 7040 medium grey),
 - Stainless steel 1.4301 (AISI 304),
 - Stainless steel 1.4571 (AISI 316Ti).
- **Legal-for-Trade design** for 3000d or multi-range 2 x 3000d
- **Optional explosion hazard design** for explosion hazard zone combinations
 - ATEX Zone 1 and 21
 - ATEX Zone 2 and 22

- The DPW Pallet Scales use the robust, tried-and-tested RTN load cells.

Big bag filling stations can be simply constructed on top of the pallet scales.

We are happy to offer further special designs that meet your particular demands.

And of course we can create a complete scales system for you consisting of a DPW Pallet Scales, DISOMAT® control and evaluation electronics and further accessories such as a printer, display, etc...

Technical Specifications

Load-carrying capacity: max. 2 000 kg
 Possible Weighing ranges:

- 4 – 600 kg / 0.2 kg
- or 10 – 1 500 kg / 0.5 kg
- or 20 – 2 000 kg / 1 kg
- or multi-range or multi-interval scales

DPW Pallet Scales are available in two sizes

Size	I	II
Placement area	1 080 x 1 250 mm	1 350 x 1 250 mm
for pallets	800 x 600 mm	1 200 x 1 000 mm
	1 000 x 800 mm	1 200 x 1 200 mm
	1 200 x 800 mm	
A	620	740
B	1080	1350
C	1480	1750

Material: St37, Stainless steel AISI 304 1.4301 – AISI 316Ti 1.4571
 Weight: approx. 250 kg

2 sizes with respect to the drive-in width

